

iwata

by ANEST IWATA

neo

for iwata

AIRBRUSH SERIES

TRN1 | TRN2
Operating Instruction Manual

NEOTRIGGER-IM-OAJ

EFFORTLESS COVERAGE™

手頃で手軽

Iwata Revolution Series and NEO For Iwata Series airbrushes deliver soft, effortless coverage at low air pressures. Fine atomization is achieved with the smallest of air compressors, making these airbrushes a simple choice for medium spray applications and for anyone wanting to start airbrushing for the first time.

NEED ASSISTANCE ?

If you have any issues or warranty service questions, contact your local ANEST IWATA affiliate before returning to your place of purchase.

ANEST IWATA-MEDEA, INC.

Portland, Oregon U.S.A.
+1-503-253-7308 (M-F)
info@iwata-medea.com
www.iwata-airbrush.com

ANEST IWATA SOUTH-EAST ASIA CO., LTD.

Bangkok, Thailand
+66-(0)-2643-2870
www.anest-iwatasoutheastasia.com

ANEST IWATA SOUTH AFRICA (PTY) LTD.

Johannesburg, Republic of South Africa
+27-11-463-2169/2265/2223
www.anest-iwata.co.za

ANEST IWATA CORPORATION

Yokohama, Japan
+81-(0)45-591-1111
www.anest-iwata.co.jp

ANEST IWATA STRATEGIC CENTER

Cardano al Campo, Italy
+39-0331-733120
www.anest-iwataeu.com

ANEST IWATA SHANGHAI

Shanghai, China
+86-(0)21-6407-9713 / 15 / 16
www.anest-iwata-sh.com

ANEST IWATA RUS LLC

Moscow, Russia
+7-495-938-77-28
www.anestiwata.ru

ANEST IWATA AUSTRALIA PTY LTD.

Mt. Druitt, NSW
+61-(02)-9853-2000
www.anest-iwata.com.au

ANEST IWATA (U.K.) LTD.

Neots Cambs, England
+44-(0)1480-405419
www.anest-iwata.co.uk

ANEST IWATA MOTHERSON LTD.

Uttar Pradesh, India
+91-(0)120-4600500 / 14 / 17
www.anest-iwata.co.jp

CENTURY TRADING CO., LTD.

Seoul, Korea
82-2-2163-0300
www.centradng.co.kr

ASSEMBLY

1. Screw the air hose onto the airbrush (Iwata air hose sold separately).
2. Screw the air hose onto the compressor.

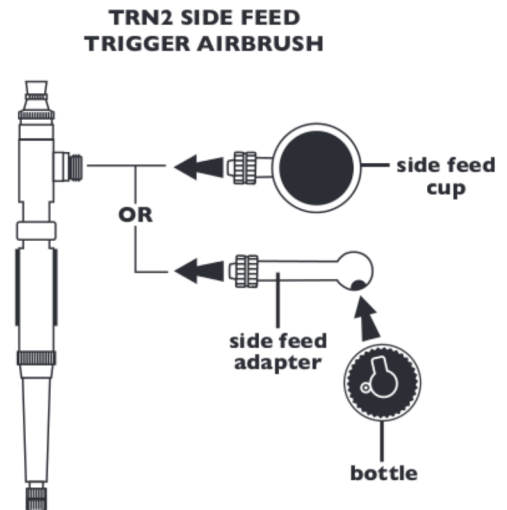
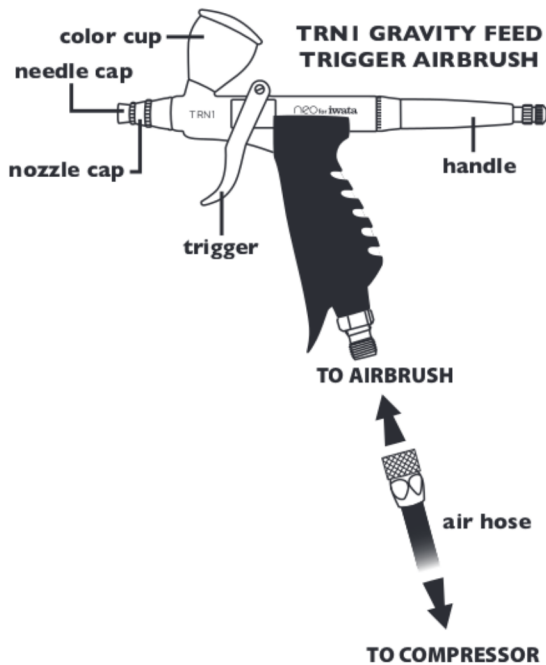

GENERAL OPERATION

Fine-Line Spray

1. Depress the main lever to start air flow.
2. Position the airbrush close to the surface, between 1/16 and 1/2 inch is common.
3. Pull the main lever back slightly to start the flow of paint.

Line thickness can be controlled by adjusting the distance between the airbrush and the surface and also by varying the paint flow by manipulating the main lever's position.

Wide-Line and Background Spraying

1. Depress the main lever.
2. Position the airbrush further away from the surface, from 1 to 6 inches is common.
3. Pull the main lever back much farther releasing more paint to cover the bigger area.

Increase the distance between the airbrush and painted surface to control the line's width. Increasing the air pressure will also affect the spray width.

Air Pressure

For the NEO, working pressures generally vary between 10 and 60 psi, depending on what type of work is being done and what textures are desired. A good working

pressure may average around 15-25 psi. The viscosity of the paint and your desired spray characteristics will also affect your ideal pressure. As a general rule, larger amounts of paint or thicker paints, will be sprayed with higher pressures.

WARNING: Do not exceed 100psi.

Paint Preparation

For non-airbrush-ready paints, proper preparation, including filtering the paint through a nylon mesh, is recommended for best performance. Paint should be thinned with its proper solvent. It is best to prepare paint relatively thin and make repeated passes across the work to achieve the desired shade. This will also improve the quality of your work and decrease the cleaning time of your airbrush.

Safety Tips

- Always spray in a well-ventilated area.
- Do not spray solvent-based (flammable) paints around open flames.
- Use the appropriate respirator to safely filter out the paint vapors particular to the kind of paint you are using.
- Wear eye protection to prevent paint contact with eyes.
- Never use air pressure that exceeds the airbrush's limit (100 psi).

MAINTENANCE

Cleaning the Airbrush (TRN2)

1. Remove the paint bottle.
2. Attach a bottle containing the appropriate cleaning solution. (Note: Medea Airbrush Cleaner works great for water-based media.)
3. Spray until the solution sprays clear.
4. Remove the bottle of cleaning solution.
5. Spray air until the airbrush sprays dry.
6. Attach a bottle containing the next color.
7. Repeat cleaning procedure when finished.

Cleaning the Airbrush (TRN1)

1. Dump out the color cup's excess paint.
2. Rinse the cup with the appropriate cleaning solution. (Note: Medea Airbrush Cleaner works great for water-based media.)
3. Use a paper towel to wipe out any left-over paint.
4. Fill the bottom of the cup with cleaner.
5. Spray cleaner until the spray is clear.
6. Add the next color to the color cup.
7. Repeat cleaning procedure when finished.

Cleaning the Needle (TRN2, TRN1)

Before removing the needle, clean the airbrush as recommended.

1. Unscrew the handle from the airbrush body.
2. Loosen the needle chucking nut.
3. Gently pull the needle straight out.
4. Fold a soft cloth damp with cleaner over the needle.
5. Rotate the needle to gently wipe the residual paint off.
6. Carefully insert the needle into the airbrush until it seats fully against the nozzle.

CAUTION: The most probable time to damage the needle is when the needle passes through the main lever. If the needle stops abruptly, retract and examine the trigger mechanism for proper assembly and re-insert the needle.

7. Tighten the needle chucking nut finger tight.
 - Pull the main lever back and forth to visually confirm the needle's ability to move.
8. Screw the handle back onto the airbrush body.

Before Each Session

Spray water or the appropriate cleaning solution through the airbrush to make sure the airbrush is working properly.

After Each Session

Or any time the airbrush becomes clogged:

1. Increase the air pressure.
2. Spray cleaning solution for a short time.
3. Clean the needle if necessary

Cleaning the airbrush this way helps clean the paint passage, the nozzle and the needle thoroughly.

Periodically

To ensure smooth main lever action lubricate the needle and the main lever mechanism when necessary.

1. Unscrew the handle.
2. Loosen the needle chucking nut.
3. Remove the needle.
4. Coat the needle lightly at the front where the taper starts with a high-quality lubricant, like Medea Super Lube.
5. Wipe the needle with a soft, clean cloth, leaving a light coat of lube behind.
6. Re-insert the needle gently into the airbrush.
7. Tighten the needle chucking nut.
8. Screw the handle onto the airbrush body.

Use a tiny drop of lube on the main lever's piston. **DO NOT** over-lube the needle

or the main lever mechanism, since it is possible to transfer excess lube into the nozzle causing severe paint flow problems. **DO NOT** use light machine oil or WD-40 for lubrication. These will cause the needle to stick as it moves through the needle packing o-ring.

CAUTION: If it becomes absolutely necessary to dismantle the airbrush remember that in most situations tools are not needed.



NEVER soak your entire airbrush in any liquid. **NEVER** store your airbrush with spray medium or cleaning agents in the fluid cup.

IMPORTANT NOZZLE INFORMATION

Never remove the nozzle unless it is damaged or clogged.

Always keep your airbrush clean. Never leave paint in your airbrush as dried paint can clog a nozzle. Although engineered from durable, high-quality materials, the nozzle is small and delicate. Accidental damage caused by cross-threading, over-tightening, dropping the airbrush, forcing a needle or tools into the nozzle and normal wear are not covered under the warranty. Replacement parts and repair services are available through your local affiliate.

NEO FOR IWATA — TRN1, TRN2

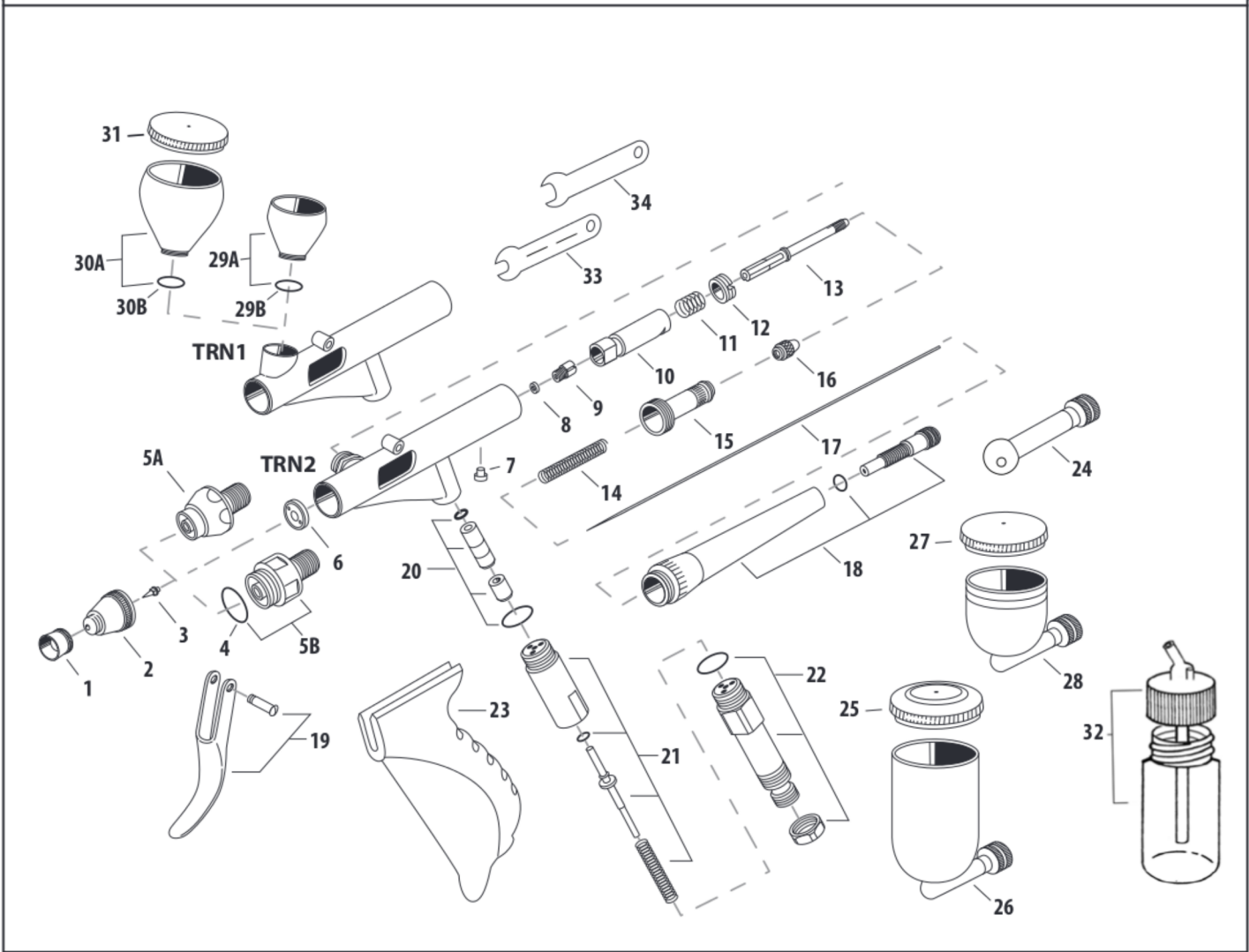

#	ITEM DESCRIPTION	PRICE CODE	ITEM #	TRN2 N 5000	TRN1 N 5500	ALSO FITS
1	Needle Cap	A	N 110 2	■	■	
2	Nozzle Cap	N3	A N 140 3	opt	■	
		N5	A N 140 4	■	opt	
3	Nozzle	N3	C N 080 3	opt	■	
		N5	C N 080 4	■	opt	
4	Nozzle Cap O-ring	A	N 150 4	■	x	
5A	Head Base	A	N 135 3	x	■	
5B	Head Base	A	N 135 4	■	x	
6	Head Base Packing (PTFE)	A	N 150 5	■	■	
7	Main Body Ring Screw	A	N 131 2	■	■	
8	Needle Packing (PTFE)	A	N 150 7	■	■	
9	Needle Packing Screw	A	N 125 2	■	■	
10	Slide Cam	A	N 130 1	■	■	
11	Spring Side Cam	A	N 130 2	■	■	
12	Main Body Ring	A	N 131 1	■	■	
13	Needle Chucking Guide	A	N 115 2	■	■	
14	Needle Spring	A	N 135 2	■	■	
15	Spring Guide	A	N 170 2	■	■	
16	Needle Chucking Nut	A	N 120 2	■	■	

#	ITEM DESCRIPTION	PRICE CODE	ITEM #	TRN2 N 5000	TRN1 N 5500	ALSO FITS
17	Needle	N3	A N 075 3	opt	■	
		N5	A N 075 4	■	opt	
18	Handle Cap Set	D	N 090 2	■	■	
19	Trigger With Trigger Screw	A	N 100 2	■	■	
20	Air Piston Set	A	N 010 1	■	■	
21	Air Valve Set	C	N 020 2	■	■	
22	Grip Mount/Extension	D	N 160 1	■	■	
23	Grip	B	N 160 2	■	■	
24	Bottle Adapter	C	N 040 1	■	x	
25	Side Cup Lid	0.50 oz / 15 ml	A N 095 2	■	x	
26	Side Cup	0.50 oz / 15 ml	A N 070 6	■	x	
27	Side Cup Lid	0.24 oz / 7 ml	A N 095 3	■	x	
28	Side Cup	0.24 oz / 7 ml	D N 070 5	■	x	
29A	Fluid Gravity Cup w/O-ring	0.05 oz / 1.50 ml	C N 070 1	x	■	NEO CN
29B	O-ring For Fluid Gravity Cup	0.05 oz / 1.50 ml	A N 071 2	x	■	NEO CN
30A	Fluid Gravity Cup w/O-ring	0.24 oz / 7 ml	D N 070 2	x	■	NEO CN
30B	O-ring For Fluid Gravity Cup	0.24 oz / 7 ml	A N 071 3	x	■	NEO CN
31	Fluid Gravity Cup Lid	0.24 oz / 7 ml	A N 095 4	x	■	NEO CN
32	Spanner		A N 165 1	x	■	NEO CN/ NEO BCN
33	Spanner		A N 165 2	■	x	

■ = yes x = no opt = optional

REPLACEMENT PARTS AND ACCESSORIES

Nozzle

In time, the nozzle may wear or be damaged and may need to be replaced.

1. Unscrew the handle.
2. Loosen the needle chucking nut.
3. Gently pull the needle part way back. It doesn't need to be fully pulled out.
4. Unscrew the needle cap and the nozzle cap.
5. Unscrew the nozzle counter-clockwise with the provided wrench.
6. Screw the new nozzle into the airbrush body with your fingers.
7. Slightly tighten the nozzle with the provided wrench.
 - DO NOT OVER TIGHTEN!
8. Screw the needle cap and nozzle cap onto the airbrush body.
9. Push the needle all the way forward until it seats with the new nozzle.
10. Tighten the needle chucking nut.
11. Screw the handle onto the airbrush body.

TIP: Keep a spare nozzle on hand for unforeseen accidents.

Needle

Needles are subject to easy physical damage because of the long tapered, extremely fine tip. If the needle point becomes severely bent, it must be straightened before pulling it back through the nozzle. If not, the bent needle might damage the nozzle as it's pulled through.

TIP: Keep a spare needle on hand for unforeseen accidents.

WARRANTY



All Iwata airbrushes are warranted against all manufacturing defects of material and manufacture or workmanship for a period of FIVE years from date of purchase. This warranty does not cover needles, nozzles, o-rings and internal packings since these parts need to be replaced occasionally due to normal wear. Any other parts or materials that are or become defective so as not to be usable within this period will be repaired or replaced. This warranty does not cover damage caused by negligence or airbrushes which have been altered or abused in any way.

iwata

by ANEST IWATA

www.iwata-airbrush.com